

**Magnetic Field Sensor
for pneumatic cylinders
BIM-UNC-AP6X**

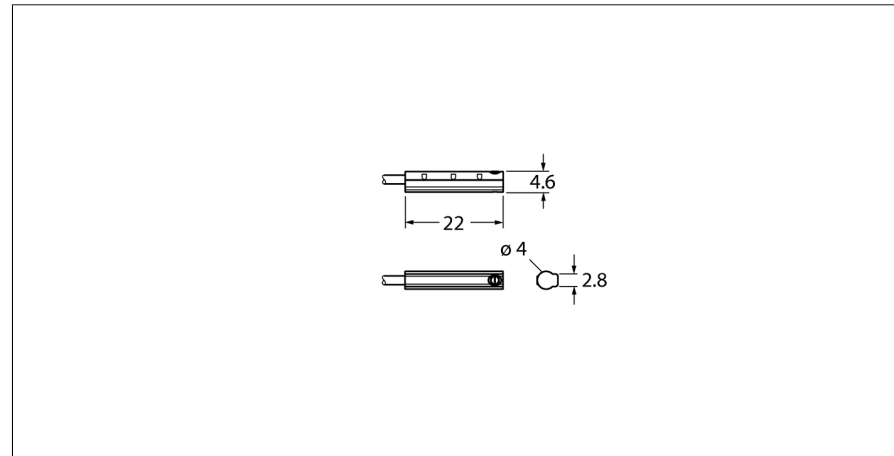

- For SMC C-groove cylinders without mounting accessories
- One-hand mounting possible
- Stable mounting
- Magneto-resistive sensor
- DC 3-wire, 11...30 VDC
- NO contact, PNP output
- Cable connection

Wiring Diagram



Functional principle

Magnetic field sensors are activated by magnetic fields and are used, in particular, for the detection of the piston position in pneumatic cylinders. As magnetic fields can permeate non-magnetizable metals, they detect a permanent magnet attached to the piston through the aluminium cylinder wall.

Derating Curve

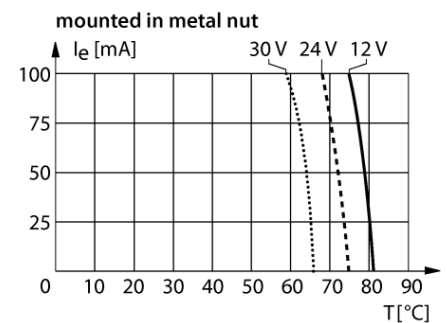
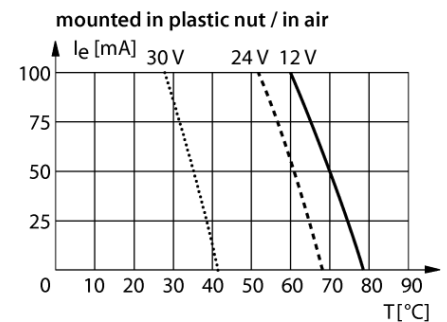

Type designation	BIM-UNC-AP6X
Ident no.	100001904
Pass speed	≤ 3 m/s
Repeatability	≥ ± 0.1 mm
Temperature drift	≤ 0.1 mm
Hysteresis	≤ 1 mm
Ambient temperature	-25...+70 °C
Operating voltage	11...30 VDC
Residual ripple	≤ 10 % U _s
DC rated operational current	≤ 100 mA
No-load current I ₀	≤ 15 mA
Residual current	≤ 0.1 mA
Isolation test voltage	≤ 0.5 kV
Short-circuit protection	yes/ Cyclic
Voltage drop at I ₀	≤ 1.8 V
Wire breakage/Reverse polarity protection	yes/ Complete
Output function	3-wire, NO contact, PNP
Switching frequency	0.3 kHz
Design	Rectangular
Dimensions	22.1 x 4.6 mm
Housing material	Plastic, PP-GF20
Active area material	plastic, PP-GF20
Tightening torque fixing screw	0.1 Nm
Electrical connection	Cable
Cable quality	2 mm, Gray, TPU, 2m
Cable cross section	3 x 0.08 mm ²
Vibration resistance	55 Hz (1 mm)
Shock resistance	30 g (11 ms)
Protection class	IP67
MTTF	2283 years acc. to SN 29500 (Ed. 99) 40 °C
Mounting on the following profiles	.
Cylindrical design	
Switching state	LED yellow
Included in delivery	Cable clip

Magnetic Field Sensor for pneumatic cylinders BIM-UNC-AP6X

TURCK

Industrial
Automation

Mounting instructions/Description

Mounting instructions

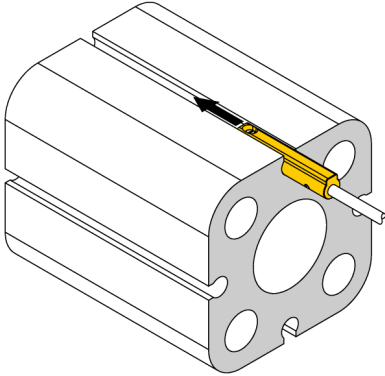

The sensor is mounted in the groove from the side. If the screw is turned clockwise, it moves out of the thread and pushes the sensor upwards towards the cylinder. This fixes the sensor in place. A quarter turn of the screw with a slotted screwdriver is sufficient to fasten the sensor so that it doesn't vibrate. A tightening torque of 0.1 Nm is sufficient for safe mounting without damaging the cylinder. A cable clip is included in the scope of delivery. It enables smooth cable routing in the groove and ensures that the cable is fastened as securely as possible. The corresponding accessories for mounting on other cylindrical housings must be ordered separately.